

Oil Level Indicator and Tube

Material

Item	Specification
Motorcraft® SAE 5W-30 Premium Synthetic Blend Motor Oil XO-5W30-QSP (US); Motorcraft® SAE 5W-30 Super Premium Motor Oil CXO-5W30-LSP12 (Canada); or equivalent	WSS-M2C929-A

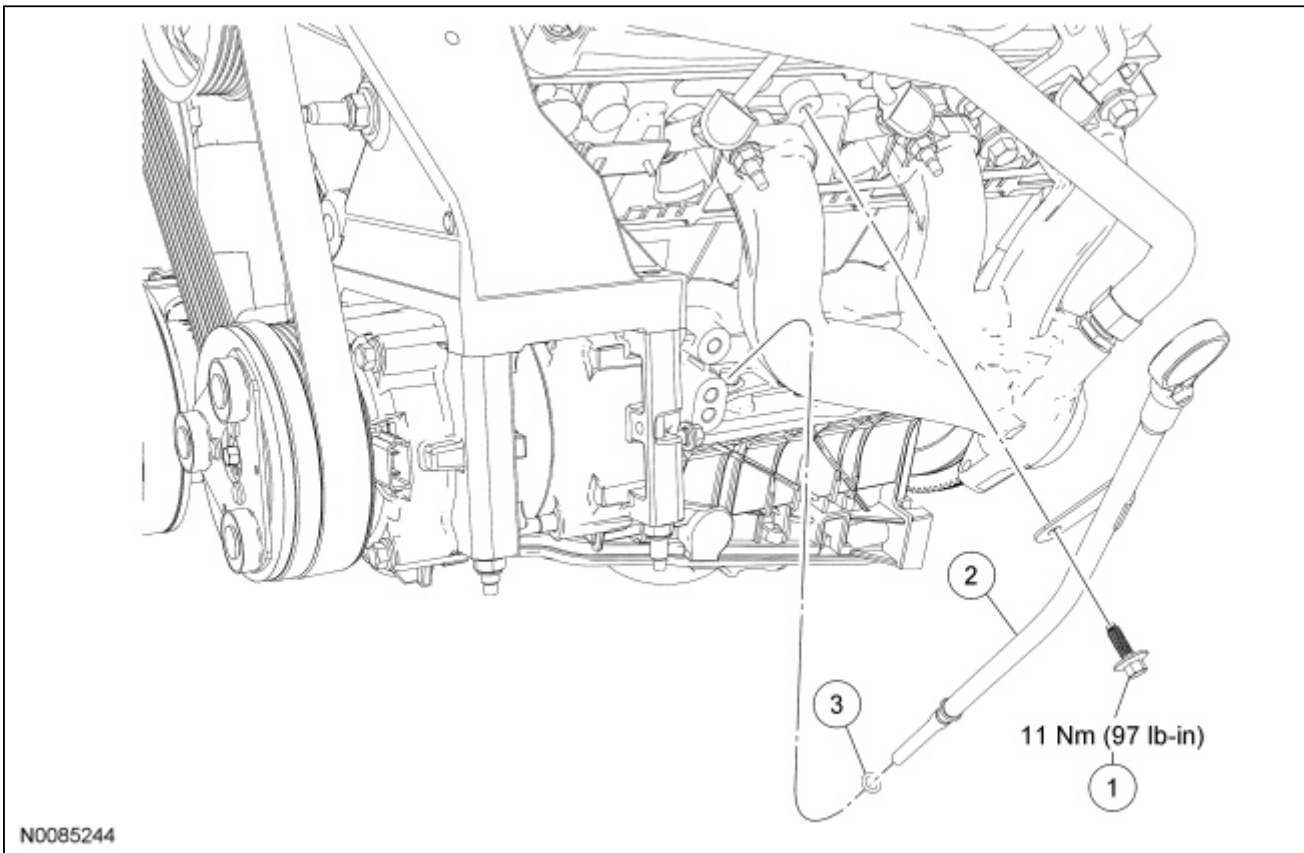

Item	Part Number	Description
1	W500213	Oil level indicator tube bolt
2	6754	Oil level indicator tube
3	—	Oil level indicator tube O-ring seal

Removal and Installation

- Remove the bolt and the oil level indicator tube.
 - To install, tighten to 11 Nm (97 lb-in).
 - Remove and discard the O-ring seal.
- NOTE:** Lubricate the O-ring seal with clean engine oil.

To install, reverse the removal procedure.

